

IN ACCORDANCE WITH ANSI/APSP/ICC-5 2011, THE INSTALLER IS RESPONSIBLE FOR PLACING ONE SKIMMER FOR EVERY 800 SQUARE FEET OF SURFACE AREA AND ONE RETURN FOR EVERY 300 SQUARE FEET OF SURFACE AREA.

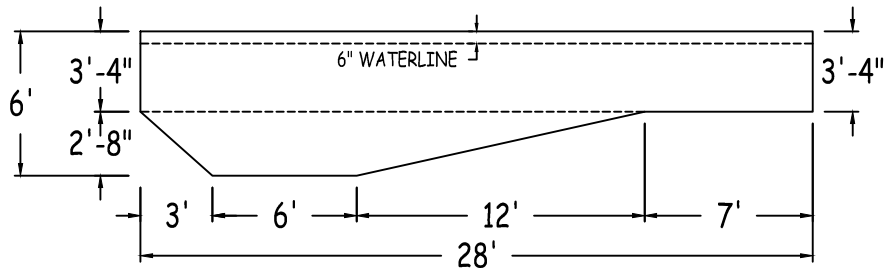
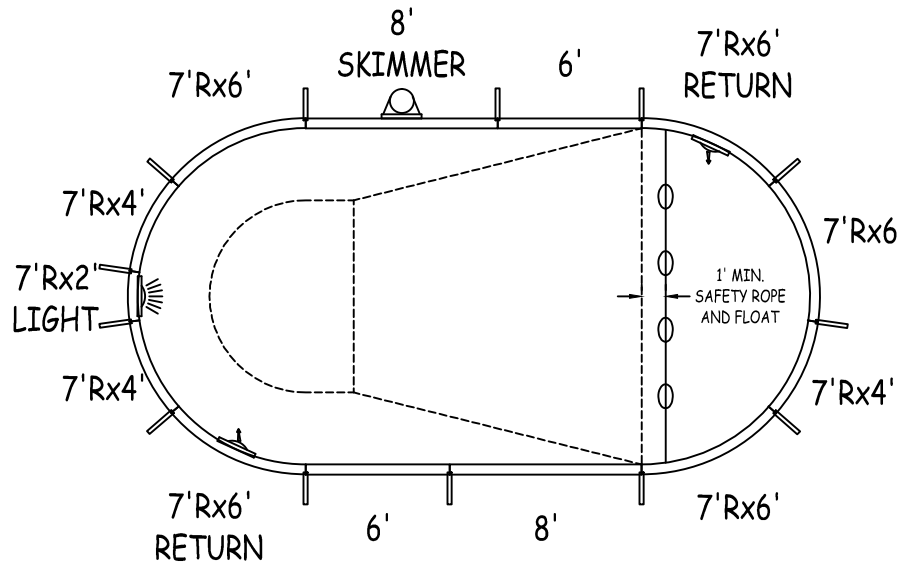
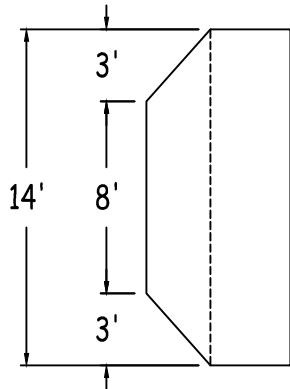

**UNIVERSAL STEEL**

**OVAL 14-0 X 28-0**

42" STEEL PANELS	PERIMETER:	72'0"	VOLUME (US Gal):	9700
DWG#:	SURFACE (ft²):	350	VOLUME (Liters):	36700
USOV00S1428-13L	LINER (ft²):	392	DATE:	1/1/2013
KIT#:	COVER (ft²):	480	DSR:	76
OV00S1428			SCALE:	1/8" = 1'-0"



**NON-DIVING POOL**

USE OF DIVING EQUIPMENT IS PROHIBITED

MEETS DEPTH AND SHAPE MINIMUM STANDARD ANSI/APSP/ICC-5 2011

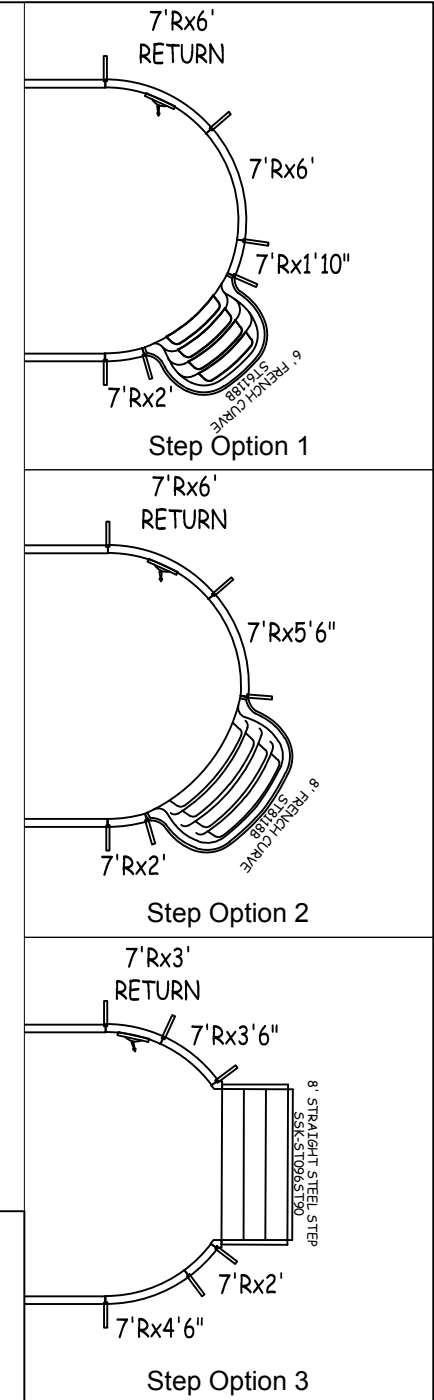

Center To Center	
1 To 2	14'0"
Diagonals	
3 To 4	14'0"
3 To 5	19'-9 1/2"
3 To 6	14'0"
4 To 5	14'0"
4 To 6	19'-9 1/2"
5 To 6	14'0"

Part number	Description	Base	Option 1	Option 2	Option 3
		QTY	QTY	QTY	QTY
ST0960002X	8'	1	1	1	1
ST0960002*	8' SKIMMER	1	1	1	1
ST0720001X	6'	2	2	2	2
RA0720841X	7'Rx6'	3	2	1	1
RA0720841*	7'Rx6' RETURN	2	2	2	1
RA0660841X	7'Rx5'6"	-	-	1	-
RA0540841X	7'Rx4'6"	-	-	-	1
RA0480841X	7'Rx4'	3	2	2	2
RA0420840X	7'Rx3'6"	-	-	-	1
RA0360840*	7'Rx3' RETURN	-	-	-	1
RA0240840*	7'Rx2' LIGHT	1	1	1	1
RA0240840X	7'Rx2'	-	1	1	1
RA0220840X	7'Rx1'10"	-	1	-	-
SSC-TR096S084R	8' STEP IN 7' RAD	-	-	-	2
Brace**	Brace	13	14	13	14
IPC-STKPK25	REBAR STAKE 18" 25PC	2	2	2	2
IPC-HDWSTR150	BOLT STR 3/8-16X1" C/W NUT 150PC	1	2	1	2
ST6118B	THKSHT STEP FRENCH CURVE 6'	-	1	-	-
ST8118B	THKSHT STEP FRENCH CURVE 8'	-	-	1	-
SSK-ST096ST90	STEEL STEP STR-90D 3 TRD 8'	-	-	-	1

\*\* RECOMMENDED BRACE: Generic (XXX-XXX)

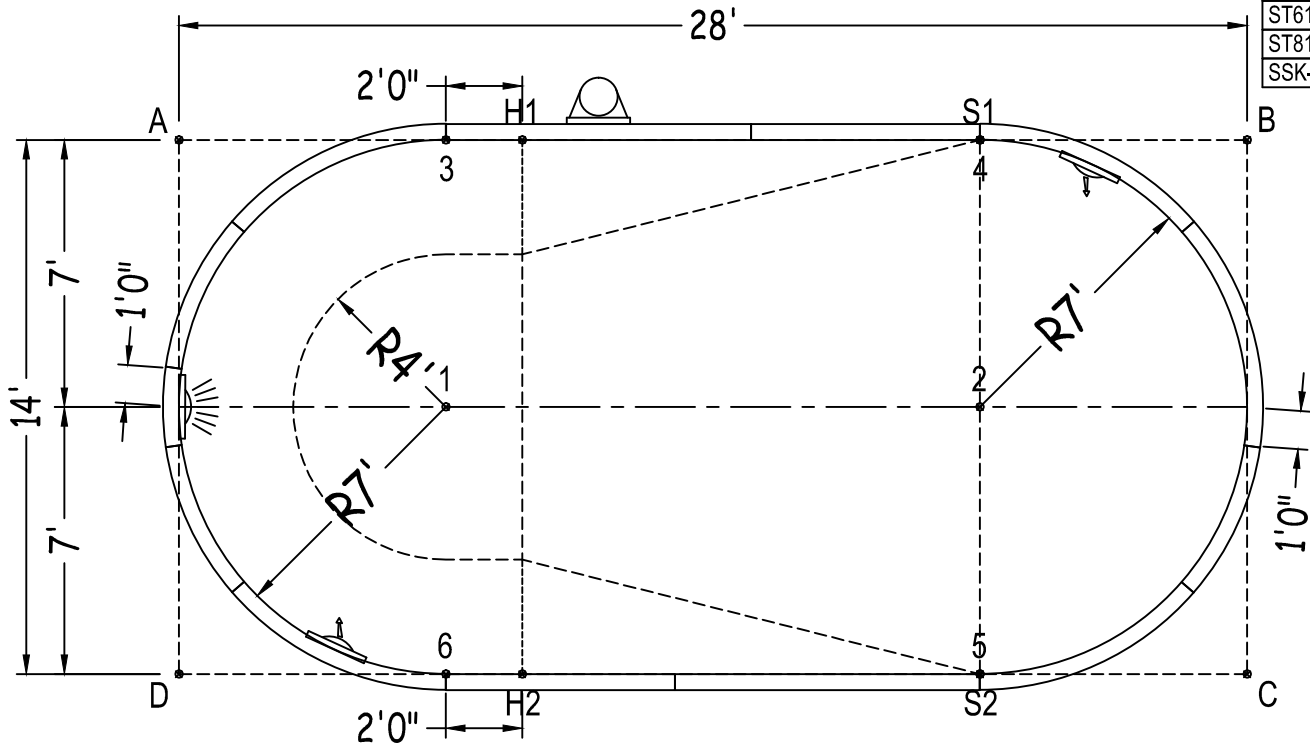

	A	B	C	D
1	9'-10 3/4"	22'-1 3/4"	22'-1 3/4"	9'-10 3/4"
2	22'-1 3/4"	9'-10 3/4"	9'-10 3/4"	22'-1 3/4"
3	7'0"	21'0"	25'-2 3/4"	15'-7 3/4"
4	21'0"	7'0"	15'-7 3/4"	25'-2 3/4"
5	25'-2 3/4"	15'-7 3/4"	7'0"	21'0"
6	15'-7 3/4"	25'-2 3/4"	21'0"	7'0"
S2	25'-2 3/4"	15'-7 3/4"	7'0"	21'0"
S1	21'0"	7'0"	15'-7 3/4"	25'-2 3/4"
H2	16'-7 3/4"	23'-7 1/4"	19'0"	9'0"
H1	9'0"	19'0"	23'-7 1/4"	16'-7 3/4"
A	-	28'0"	31'-3 3/4"	14'0"

OVAL 14-0 X 28-0

DWG #: USOV00S1428-13L

DATE: 1/1/2013

SHEET: 2 OF 3

QTY	PART #	DESCRIPTION
2	ST096000-1	8'-0" STRAIGHT
2	ST072000-1	6'-0" STRAIGHT
4	RA096084-1	8'-0" X 7'-0" RADIUS
2	RA096084-1	6'-0" X 7'-0" RADIUS [8' TRIMMED]
14	CLIP-1	COPING CLIP
1	COP-TSPK100	SCREW, TEK (100/BAG)
NOTE: SOME COPING PIECES MAY NEED TO BE TRIMMED TO LENGTH AS INDICATED		

