

IN ACCORDANCE WITH ANSI/APSP/ICC-5 2011, THE INSTALLER IS RESPONSIBLE FOR PLACING ONE SKIMMER FOR EVERY 800 SQUARE FEET OF SURFACE AREA AND ONE RETURN FOR EVERY 300 SQUARE FEET OF SURFACE AREA.

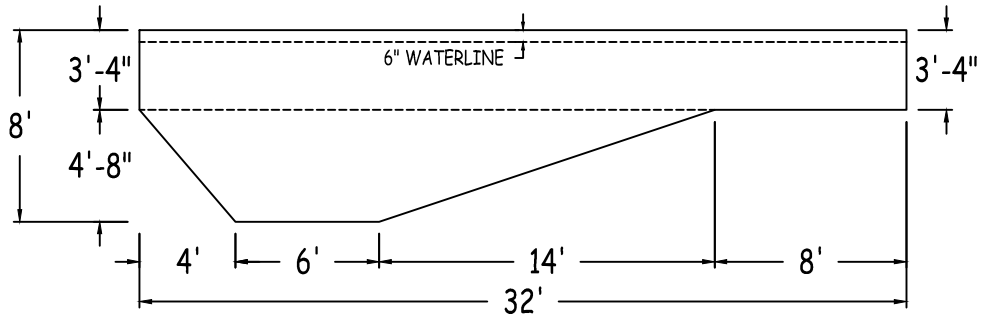

UNIVERSAL STEEL	RECTANGLE-6IN RAD 16-0 X 32-0			
42" STEEL PANELS	PERIMETER:	96'0"	VOLUME (US Gal):	16800
DWG#:	SURFACE (ft²):	512	VOLUME (Liters):	63600
USRE06S1632-13L	LINER (ft²):	512	DATE:	1/1/2013
KIT#:	COVER (ft²):	612	DSR:	76
RE06S1632			SCALE:	1/8" = 1'-0"

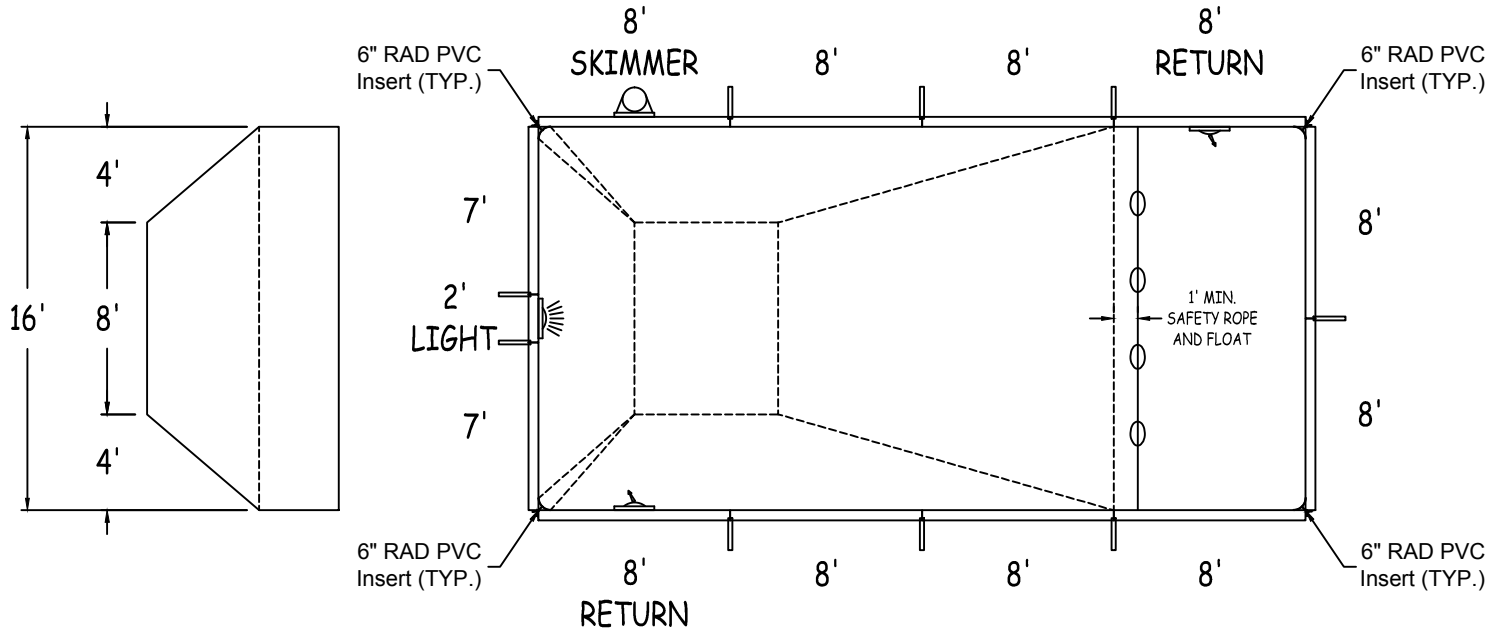

DIVING/SLIDING EQUIPMENT SHALL BE DESIGNED FOR SWIMMING POOLS AND SHALL BE INSTALLED IN ACCORDANCE WITH THE DIVING/SLIDING EQUIPMENT MANUFACTURER'S SPECIFICATIONS. PLEASE CONTACT THE DIVING/SLIDING EQUIPMENT MANUFACTURER FOR THEIR SPECIFICATIONS.

MEETS DEPTH AND SHAPE MINIMUM STANDARD ANSI/APSP/ICC-5 2011

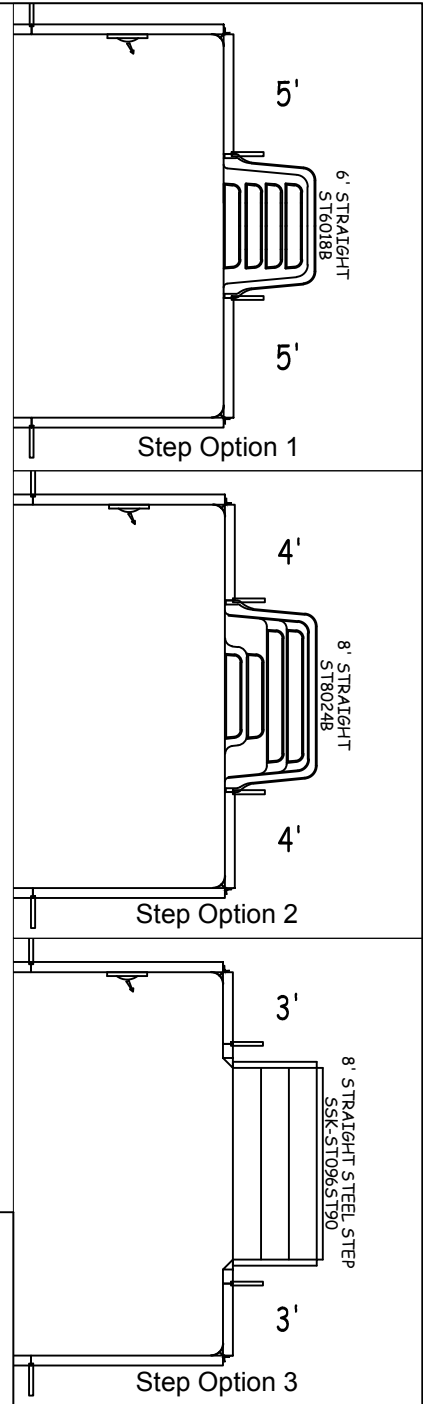

RECTANGLE-6IN RAD

Diagonals	
1 To 2	32'0"
1 To 3	35'-9 1/4"
1 To 4	16'0"
2 To 3	16'0"
2 To 4	35'-9 1/4"
3 To 4	32'0"

Part number	Description	Base	Option 1	Option 2	Option 3
		QTY	QTY	QTY	QTY
ST0960002X	8'	7	5	5	5
ST0960002*	8' SKIMMER	1	1	1	1
ST0960002*	8' RETURN	2	2	2	2
ST0840002X	7'	2	2	2	2
ST0600001X	5'	-	2	-	-
ST0480001X	4'	-	-	2	-
ST0360000X	3'	-	-	-	2
ST0240000*	2' LIGHT	1	1	1	1
SSC-TRST1207	12" Straight Transition	-	-	-	2
Brace**	Brace	9	10	10	10
IPC-AB90	CONNECTOR CNR ANGLE 90D 42"	4	4	4	4
IPC-AB90-INS6R	CORNER INSERT 6" RAD PVC 42"	4	4	4	4
IPC-STKPK25	REBAR STAKE 18" 25PC	1	1	1	2
IPC-HDWSTRT150	BOLT STR 3/8-16X1" C/W NUT 150PC	1	1	1	2
ST6018B	THKSH T STEP STR 6'	-	1	-	-
ST8024B	THKSH T STEP STR SIT N STEP 8'	-	-	1	-
SSK-ST096ST90	STEEL STEP STR-90D 3 TRD 8'	-	-	-	1

** RECOMMENDED BRACE: Generic (XXX-XXX)

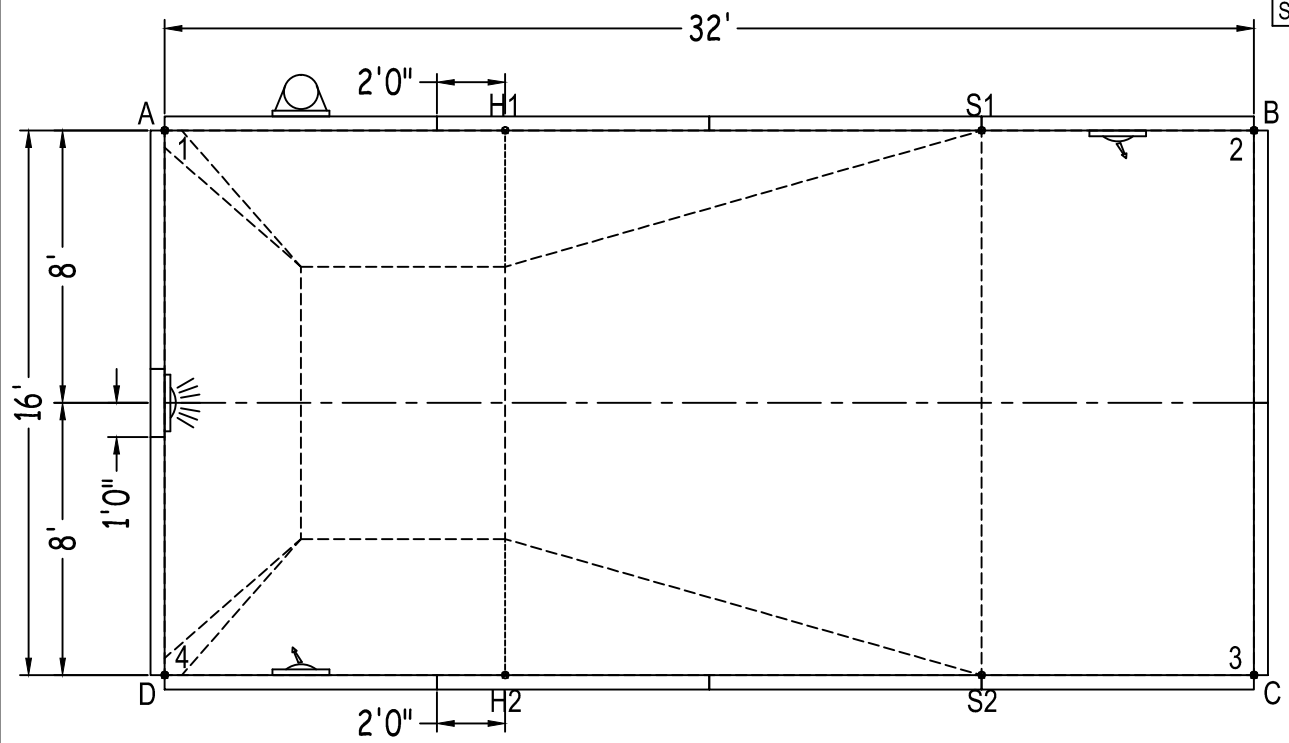

	A	B	C	D
1	0"	32'0"	35'-9 1/4"	16'0"
2	32'0"	0"	16'0"	35'-9 1/4"
3	35'-9 1/4"	16'0"	0"	32'0"
4	16'0"	35'-9 1/4"	32'0"	0"
S2	28'-10 1/4"	17'-10 3/4"	8'0"	24'0"
S1	24'0"	8'0"	17'-10 3/4"	28'-10 1/4"
H2	18'-10 1/2"	27'-2 1/2"	22'0"	10'0"
H1	10'0"	22'0"	27'-2 1/2"	18'-10 1/2"
A	-	32'0"	35'-9 1/4"	16'0"

QTY	PART #	DESCRIPTION
4	CN000006-1	6" RADIUS CORNER PIECE
8	ST096000-1	8'-0" STRAIGHT
4	ST048000-1	4'-0" STRAIGHT
20	CLIP-1	COPING CLIP
1	COP-TSPK100	SCREW, TEK (100/BAG)
NOTE: SOME COPING PIECES MAY NEED TO BE TRIMMED TO LENGTH AS INDICATED		

