

IN ACCORDANCE WITH ANSI/APSP/ICC-5 2011, THE INSTALLER IS RESPONSIBLE FOR PLACING ONE SKIMMER FOR EVERY 800 SQUARE FEET OF SURFACE AREA AND ONE RETURN FOR EVERY 300 SQUARE FEET OF SURFACE AREA.

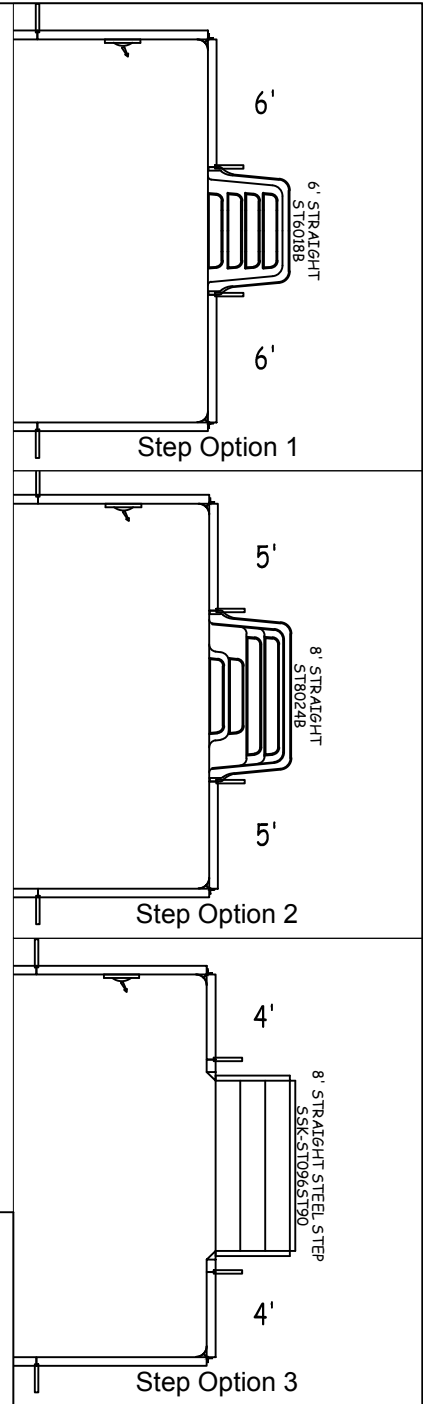

<b>UNIVERSAL STEEL</b>	<b>RECTANGLE-6IN RAD 18-0 X 36-0</b>			
42" STEEL PANELS	PERIMETER:	108'1"	VOLUME (US Gal):	21300
DWG#:	SURFACE (ft²):	648	VOLUME (Liters):	80600
<b>USRE06S1836-13L</b>	LINER (ft²):	648	DATE:	1/1/2013
KIT#:	COVER (ft²):	760	DSR:	76
RE06S1836	SCALE:	1/8" = 1'-0"		

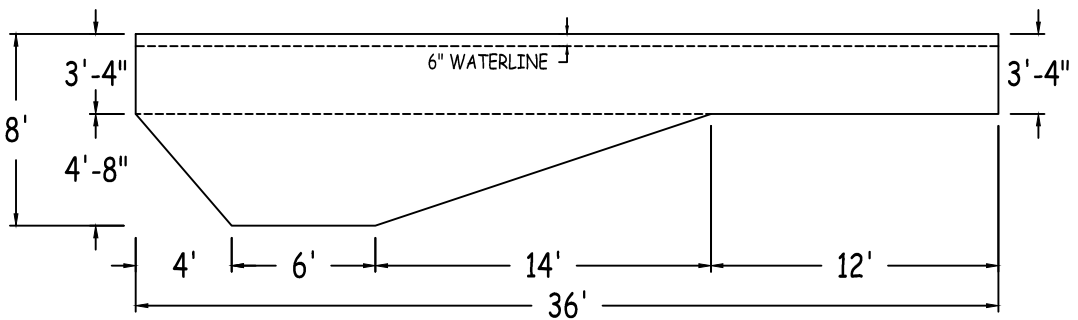
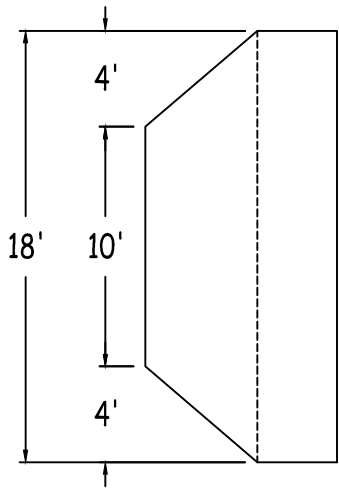
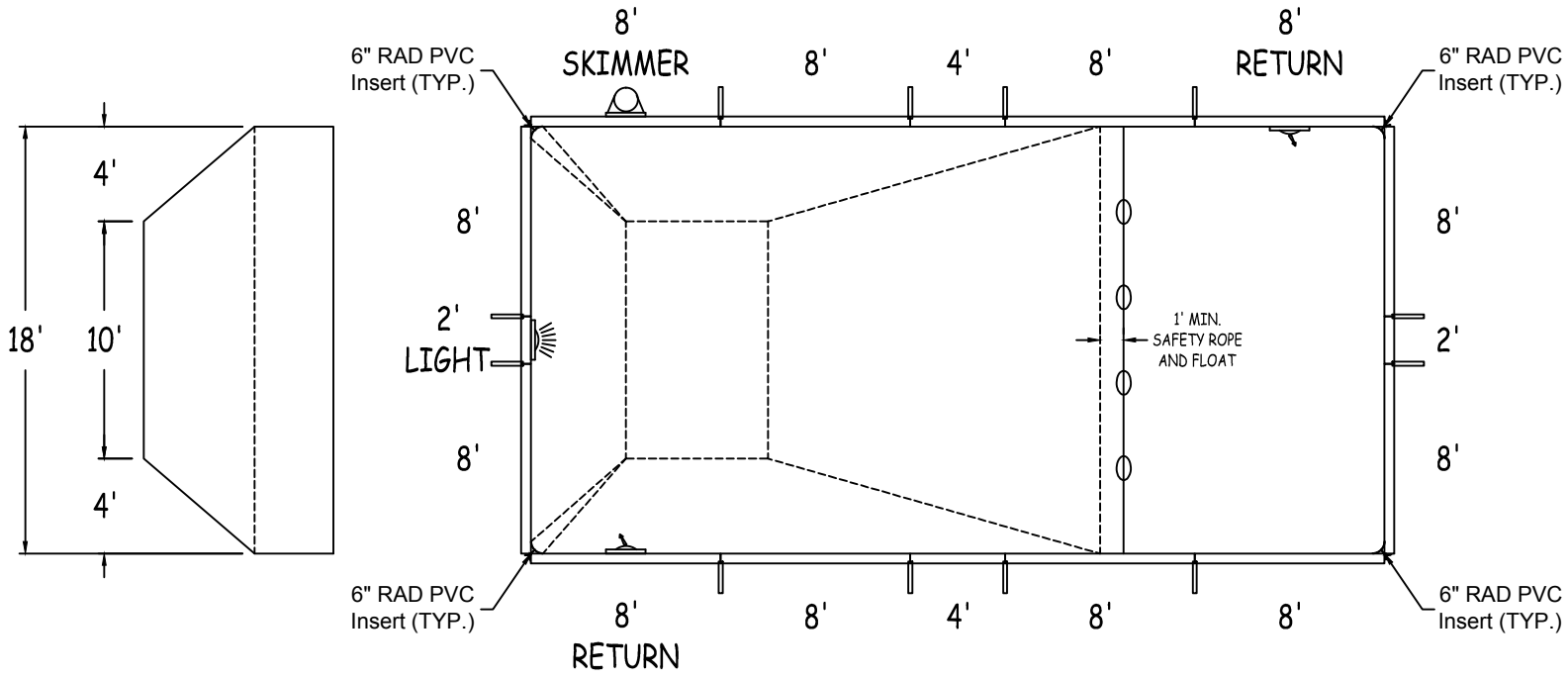

DIVING/SLIDING EQUIPMENT SHALL BE DESIGNED FOR SWIMMING POOLS AND SHALL BE INSTALLED IN ACCORDANCE WITH THE DIVING/SLIDING EQUIPMENT MANUFACTURER'S SPECIFICATIONS. PLEASE CONTACT THE DIVING/SLIDING EQUIPMENT MANUFACTURER FOR THEIR SPECIFICATIONS.

MEETS DEPTH AND SHAPE MINIMUM STANDARD ANSI/APSP/ICC-5 2011

**RECTANGLE-6IN RAD**

Diagonals	
1 To 2	36'0"
1 To 3	40'-3"
1 To 4	18'0"
2 To 3	18'0"
2 To 4	40'-3"
3 To 4	36'0"

Part number	Description	Base	Option 1	Option 2	Option 3
		QTY	QTY	QTY	QTY
ST0960002X	8'	9	7	7	7
ST0960002*	8' SKIMMER	1	1	1	1
ST0960002*	8' RETURN	2	2	2	2
ST0720001X	6'	-	2	-	-
ST0600001X	5'	-	-	2	-
ST0480001X	4'	2	2	2	4
ST0240000X	2'	1	-	-	-
ST0240000*	2' LIGHT	1	1	1	1
SSC-TRST1207	12" Straight Transition	-	-	-	2
Brace**	Brace	12	12	12	12
IPC-AB90	CONNECTOR CNR ANGLE 90D 42"	4	4	4	4
IPC-AB90-INS6R	CORNER INSERT 6" RAD PVC 42"	4	4	4	4
IPC-STKPK25	REBAR STAKE 18" 25PC	2	2	2	2
IPC-HDWSTRT150	BOLT STR 3/8-16X1" C/W NUT 150PC	2	2	2	2
ST6018B	THKSHT STEP STR 6'	-	1	-	-
ST8024B	THKSHT STEP STR SIT N STEP 8'	-	-	1	-
SSK-ST096ST90	STEEL STEP STR-90D 3 TRD 8'	-	-	-	1

\*\* RECOMMENDED BRACE: Generic (XXX-XXX)

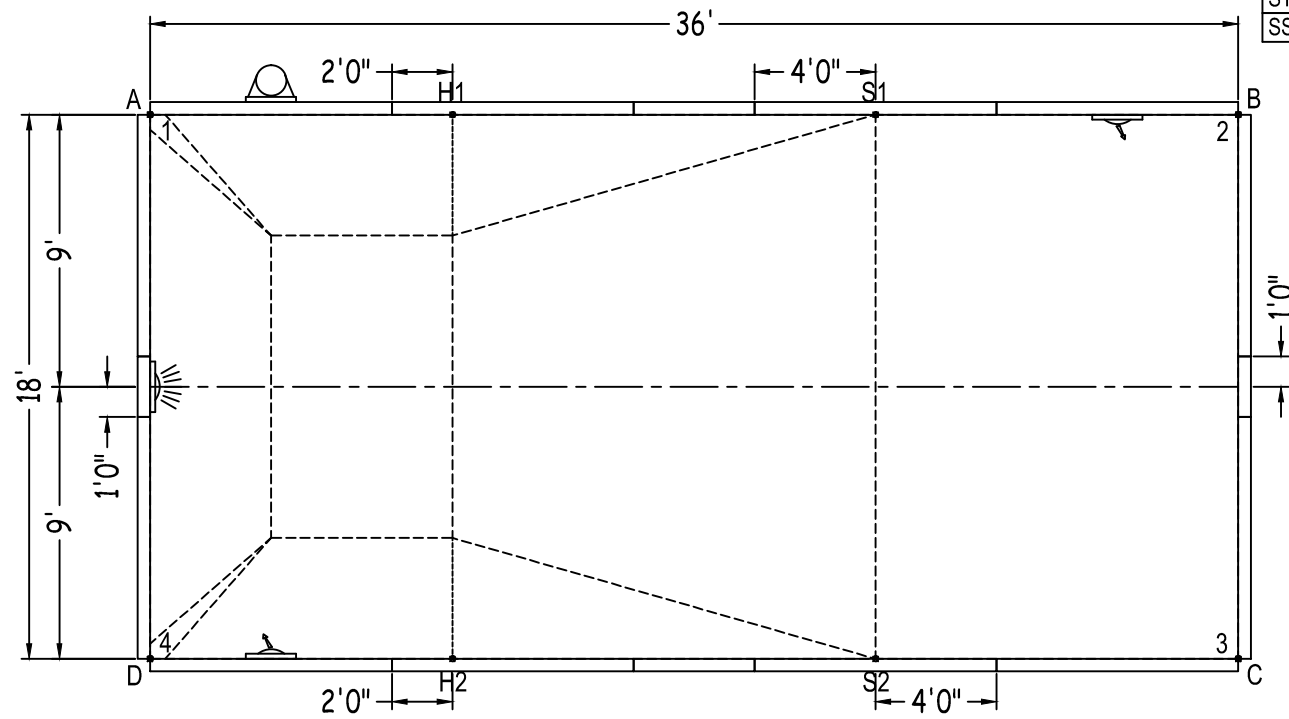

	A	B	C	D
1	0"	36'0"	40'-3"	18'0"
2	36'0"	0"	18'0"	40'-3"
3	40'-3"	18'0"	0"	36'0"
4	18'0"	40'-3"	36'0"	0"
S2	30'0"	21'-7 1/2"	12'0"	24'0"
S1	24'0"	12'0"	21'-7 1/2"	30'0"
H2	20'-7"	31'-7 1/2"	26'0"	10'0"
H1	10'0"	26'0"	31'-7 1/2"	20'-7"
A	-	36'0"	40'-3"	18'0"

QTY	PART #	DESCRIPTION
4	CN000006-1	6" RADIUS CORNER PIECE
10	ST096000-1	8'-0" STRAIGHT
2	ST072000-1	6'-0" STRAIGHT
20	CLIP-1	COPING CLIP
2	COP-TSPK100	SCREW, TEK (100/BAG)
NOTE: SOME COPING PIECES MAY NEED TO BE TRIMMED TO LENGTH AS INDICATED		

