

ROCKY'S EAZY ROLLERS INSTRUCTIONS - #5A PORTABLE

NOTE: Self Drilling Self Tapping screws require that you use an electric drill. Apply pressure to drill until the screw starts to cut it's own hole. Slowly allow it to cut screw thread. Don't overtighten screw.

This box contains the following items:

ITEM #	QTY	DESCRIPTION	RE-ORDER #
1	12	Self-tapping Screw	501
5	2	5/16"x1" Bolt	505
13	2	3/8"x 8" Anchor Bolt	513
15	2	Concrete Anchor	515
19	2	5/16" Washer	505
21	4	3/8" Washer	21
25	2	Spring	517
29	4	Acorn Nut	523
55	2	#3 A-Frame	55
61	1	White Knob	533
69	2	3" Hub	543
73	1	Large Handle	547
101	10	Male Grommet	549
103	10	Female Grommet	549
105	2	Plastic Bushing	555
107	2	Plastic Washer	555
109	2	Spring Guard	109
203	1	36' Strapping	589
211	4	4" Wheels	585

Tools Required:

Reversible Electric Drill
1/2" Concrete (masonry) Drill Bit
Hammer & Center Punch or Nail
5/16" Hex Head Socket Bit
7/16" Wrench
5/8" Wrench

1 Assemble adjustable tubes according to "adjustable tube instructions" included with tubing.

NOTE:

Tube length should be about 1' wider than pool. Insert a 3" hub (item # 69) into one end of the adjustable tubing.

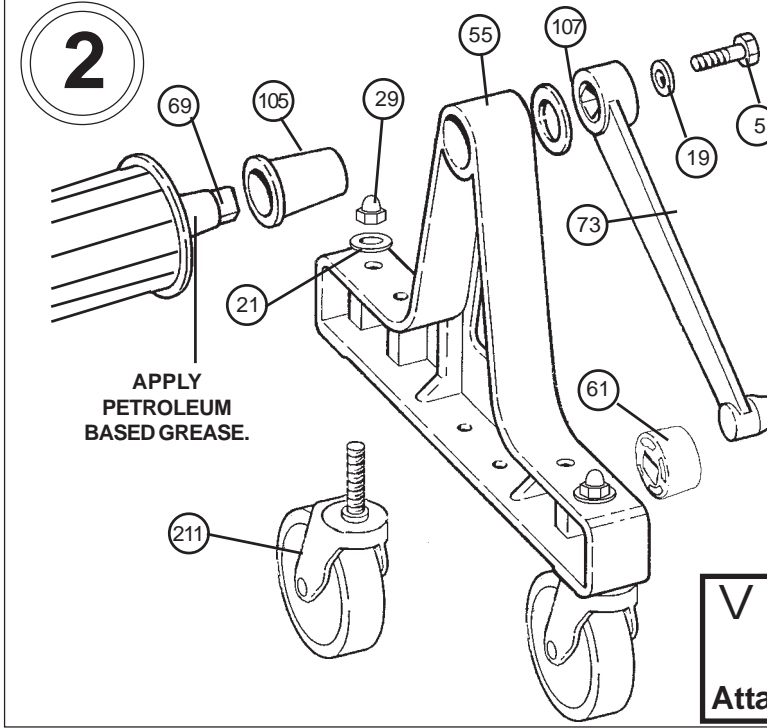
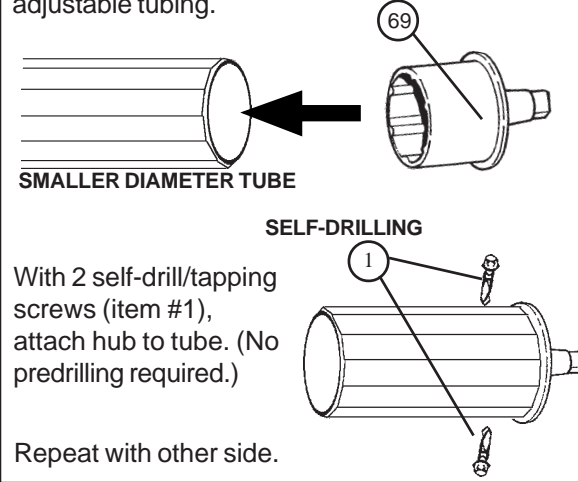

Bolt the castors (item #211) to the A-frames (item #55), as shown in the diagram.

Assemble one end unit to the tube, using the large handle (item #73), as shown in the diagram.

Assemble the other end unit to the tube, using the white knob (item #61).

For smoother operation, apply petroleum based grease between the hub (item #65) and the black bushing (item #105). This should be done once a year.

Position the assembled roller unit at the widest end of the pool.

VERY IMPORTANT
PREVENT DROWNING
Attach Warning Label to one end of tube.

3

For regular shaped pools, align the outside edge of the tube parallel with the end of the pool.

For irregular shaped pools, the outside edge of the tube should be 3' inside from the end of the pool.

4

MARK #1

MARK #2

Using one of the two holes in the A-frame as a guide, make mark #1 on deck. With a 1/2" concrete drill bit, drill a 1 1/2" deep hole at mark #1. Complete steps 5 and 6 before continuing with step 4. On the other side of the roller unit, make mark #2 by using one of the two holes in the A-frame as of guide. With a 1/2" concrete drill bit, drill a 1 1/2" deep hole at mark #2.

NOTE:
Set one bolt at front of frame on one end and one bolt at the rear of the frame on the other end.

5 Drive the concrete anchor into the hole with a hammer. Leave the anchor raised 1/16".

To set the concrete anchor, hit the slug with a hammer and center punch, or large nail, driving the slug down into the anchor forcing legs out into concrete.

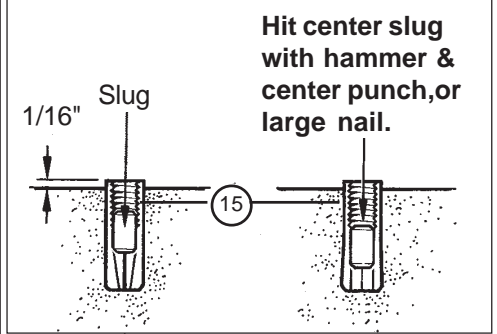

6 Insert the anchor bolt (item #11) through the spring (item #25), through the spring guard (item #109) and through the hole of the A-frame.

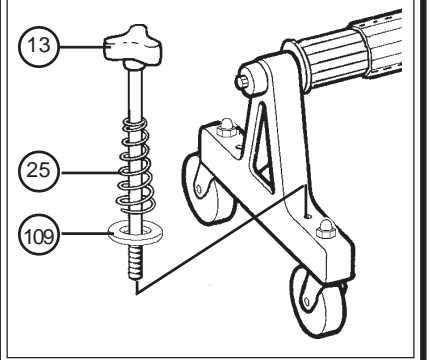

FOR REGULAR SHAPED INGROUND POOLS

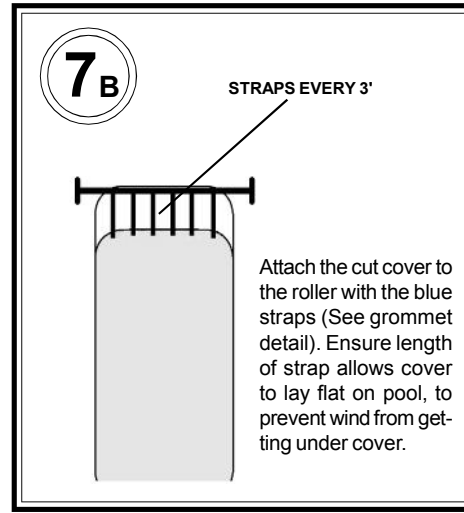
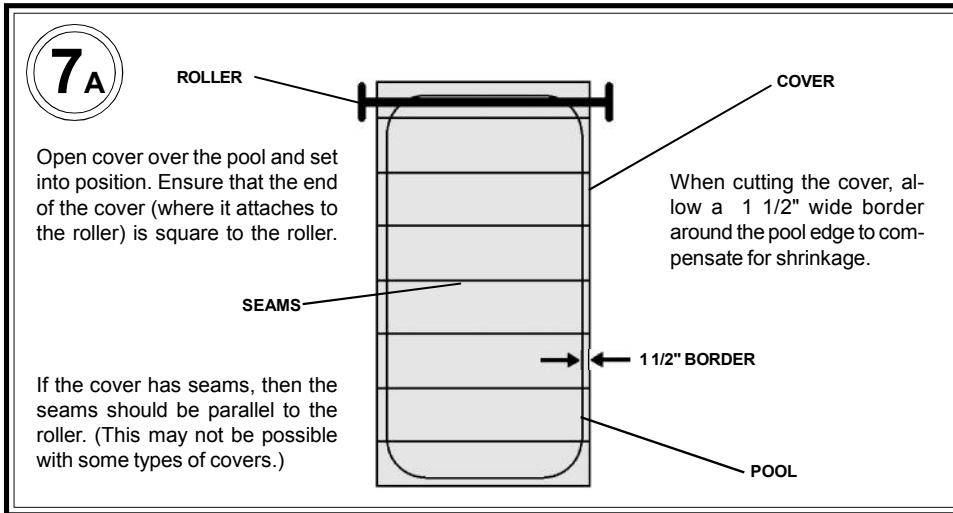

GROMMET DETAIL

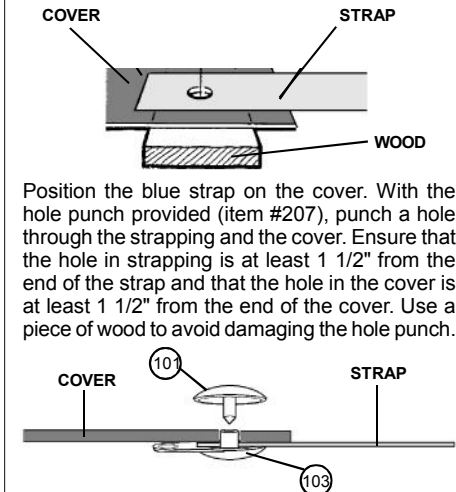

Position the blue strap on the cover. With the hole punch provided (item #207), punch a hole through the strapping and the cover. Ensure that the hole in strapping is at least 1 1/2" from the end of the strap and that the hole in the cover is at least 1 1/2" from the end of the cover. Use a piece of wood to avoid damaging the hole punch.

Insert female grommet (item #103) through hole in strapping and cover. Ensure that material is completely pushed down shaft. Insert male grommet (item #101) into female grommet. Once in place, hit gently with hammer until secure. (Caution - excess force will break grommet).

For odd shaped pools, pinch the cover and attach the strap as shown.

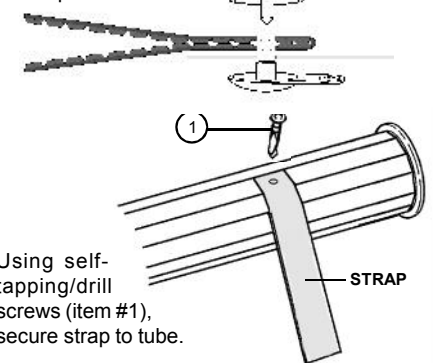

FOR IRREGULAR, KIDNEY, OR ROUND SHAPED INGROUND POOLS

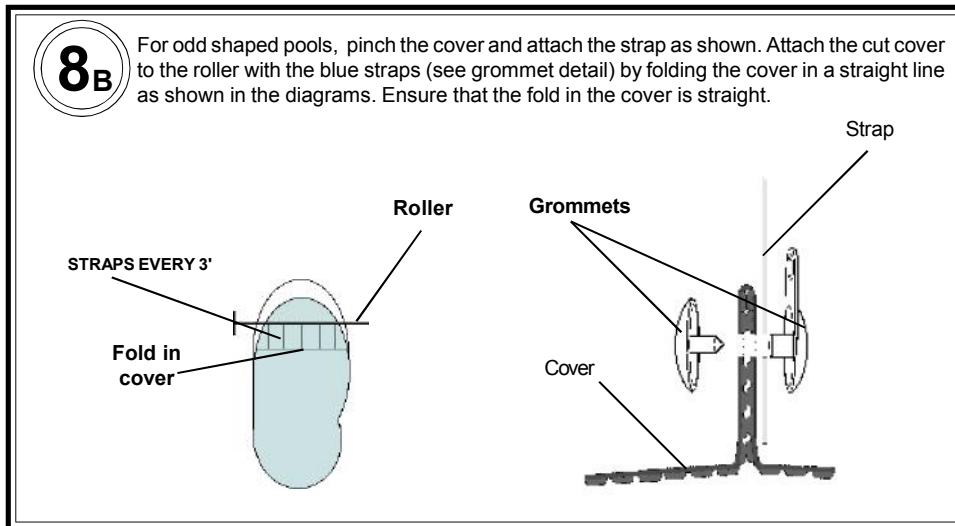
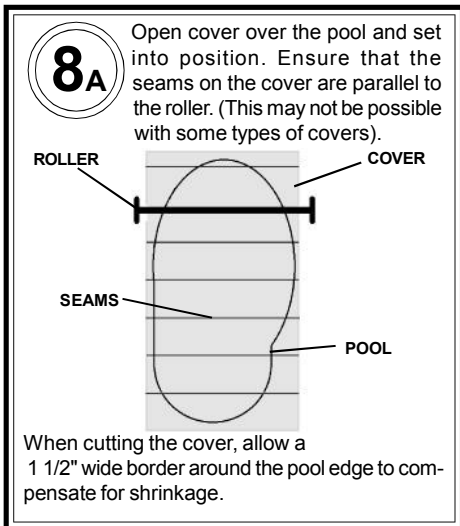

ROCKY'S REEL SYSTEMS INC.

Tel: (604) 985-0525

Fax: (604) 985-4325

North America: Tel: 1-800-663-8705 Fax: 1-800-811-9966 Web Site: www.rockyrollers.com E-Mail: info@rockyrollers.com