

IN ACCORDANCE WITH ANSI/APSP/ICC-5 2011, THE INSTALLER IS RESPONSIBLE FOR PLACING ONE SKIMMER FOR EVERY 800 SQUARE FEET OF SURFACE AREA AND ONE RETURN FOR EVERY 300 SQUARE FEET OF SURFACE AREA.

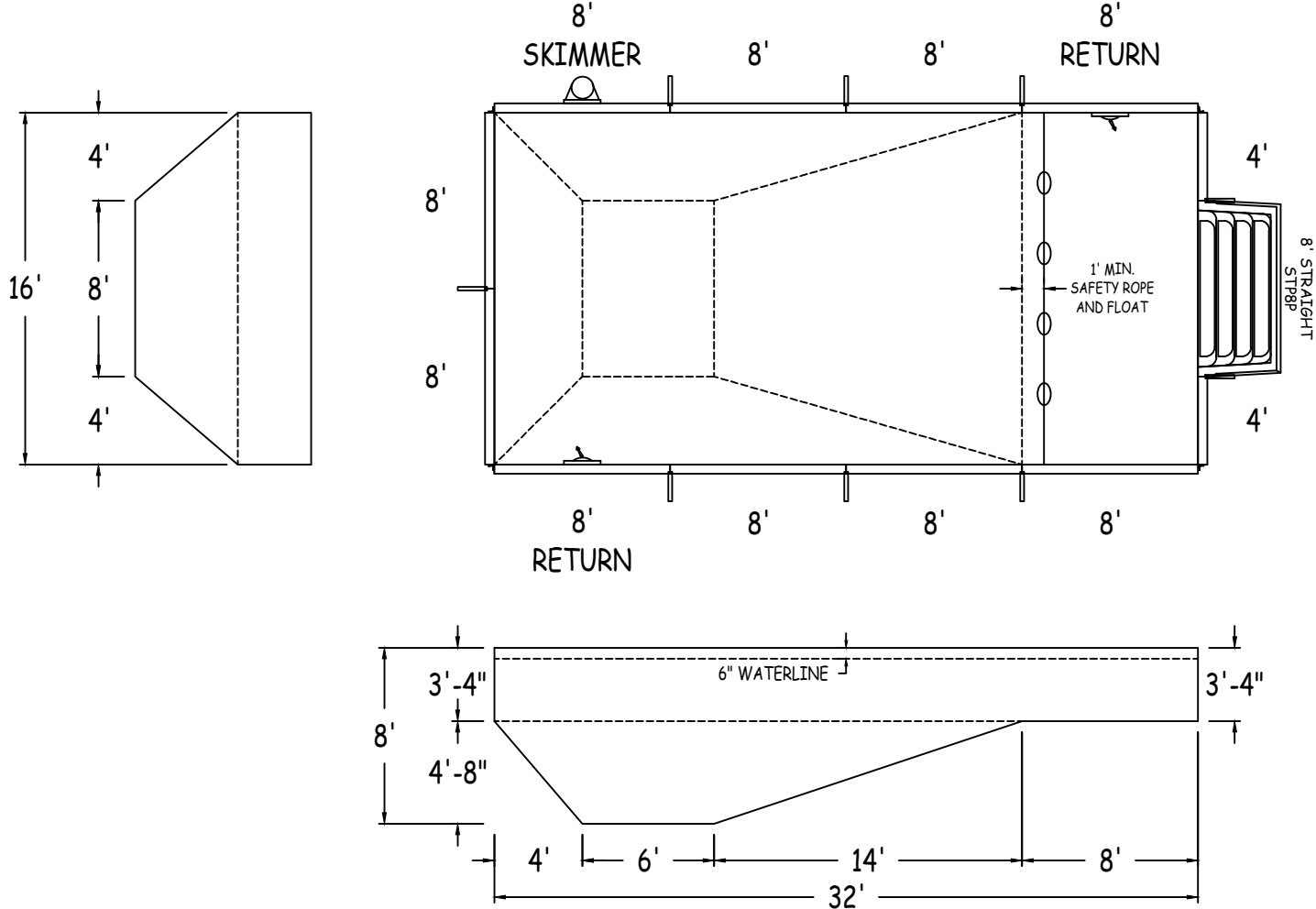

Radius Panel Length: 0 FT 0 IN
 Straight Panel Length: 88 FT 0 IN

LATHAM STEEL

RECTANGLE 90DEG 16-0 x 32-0

42" STEEL PANELS

PERIMETER: 96'-0" VOLUME (US Gal): 16800

DWG#: 2026-SPL-01633

SURFACE (ft²): 512 VOLUME (Liters): 63600

KIT#: CUSTOMKIT

LINER (ft²): 512 DATE: 1/14/2026 DSR:

COVER (ft²): 612 SCALE: 1/8" = 1'-0"



DIVING/SLIDING EQUIPMENT SHALL BE DESIGNED FOR SWIMMING POOLS AND SHALL BE INSTALLED IN ACCORDANCE WITH THE DIVING/SLIDING EQUIPMENT MANUFACTURER'S SPECIFICATIONS. PLEASE CONTACT THE DIVING/SLIDING EQUIPMENT MANUFACTURER FOR THEIR SPECIFICATIONS.

CUSTOMER: AQUIFORM EAST (BRANTFORD)
 JOB NAME: PSC #3 2

ALL ASPECTS OF THIS DRAWING COMPLIES WITH ANSI/APSP/ICC-5 2011 AND ISPSC EDITIONS 2018, 2021, & 2024

RECTANGLE

Diagonals		3 to 6	34'-2"
S1 to S2	16'-0"	4 to 5	4'-0"
H1 to H2	16'-0"	4 to 6	32'-3"
S1 to H1	14'-0"	5 to 6	32'-0"
S2 to H2	14'-0"		
S1 to H2	21'-3"		
H1 to S2	21'-3"		
1 to 2	32'-0"		
1 to 3	32'-3"		
1 to 4	34'-2"		
1 to 5	35'-9 1/4"		
1 to 6	16'-0"		
2 to 3	4'-0"		
2 to 4	12'-0"		
2 to 5	16'-0"		
2 to 6	35'-9 1/4"		
3 to 4	8'-0"		
3 to 5	12'-0"		

		Base
Part number	Description	QTY
ST0960002X	8'	7
ST0960002*	8' SKIMMER	1
ST0960002*	8' RETURN	2
ST0480001X	4'	2
Brace	Brace	9
IPC-AB90	CONNECTOR CNR ANGLE 90D 42"	4
IPC-STKPK25	REBAR STAKE 18" 25PC	1
IPC-HDWSTR150	BOLT STR 3/8-16X1" C/W NUT 150PC	1
STP8P	ACRYLIC STEP STRAIGHT 8'	1

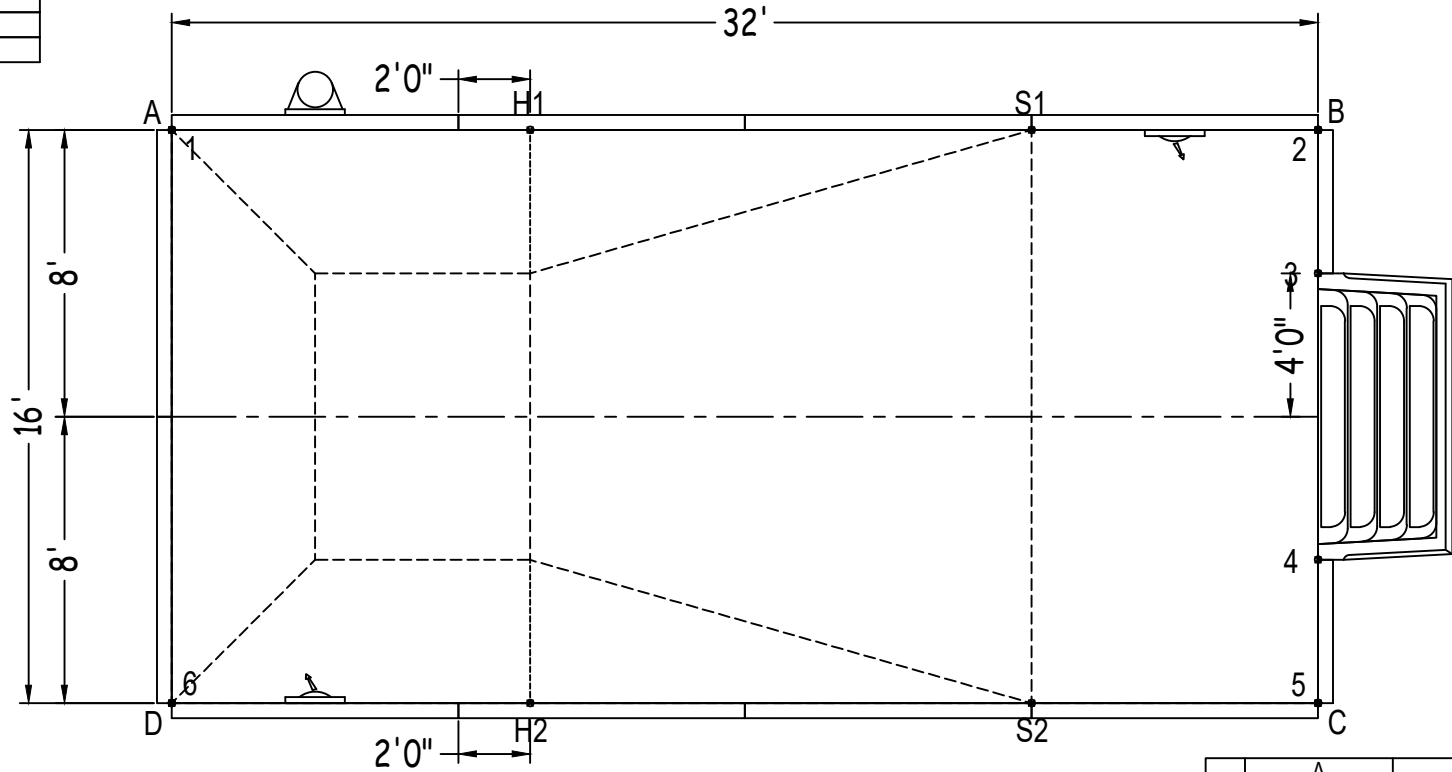

	A	B	C	D
1	0"	32'-0"	35'-9 1/4"	16'-0"
2	32'-0"	0"	16'-0"	35'-9 1/4"
3	32'-3"	4'-0"	12'-0"	34'-2"
4	34'-2"	12'-0"	4'-0"	32'-3"
5	35'-9 1/4"	16'-0"	0"	32'-0"
6	16'-0"	35'-9 1/4"	32'-0"	0"
S2	28'-10 1/4"	17'-10 3/4"	8'-0"	24'-0"
S1	24'-0"	8'-0"	17'-10 3/4"	28'-10 1/4"
H2	18'-10 1/2"	27'-2 1/2"	22'-0"	10'-0"
H1	10'-0"	22'-0"	27'-2 1/2"	18'-10 1/2"
A	-	32'-0"	35'-9 1/4"	16'-0"